

# PAR 280 PLC

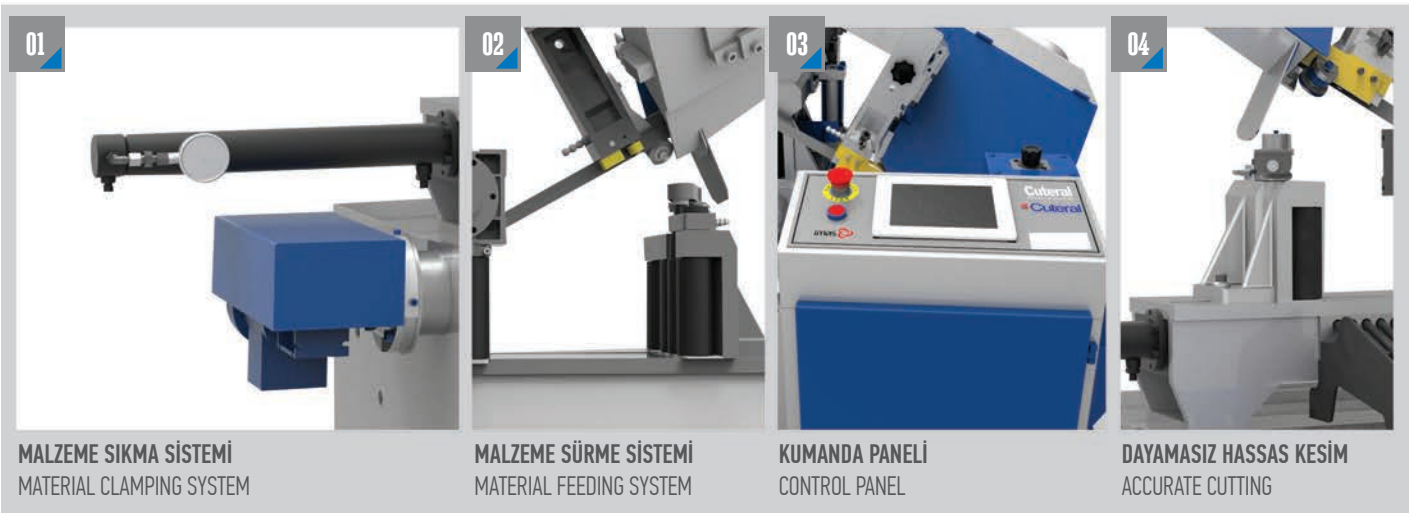

## TAM OTOMATİK PLC KONTROLLÜ TESTERE TEZGAHI FULL AUTOMATIC PLC CONTROL BANDSAW MACHINE







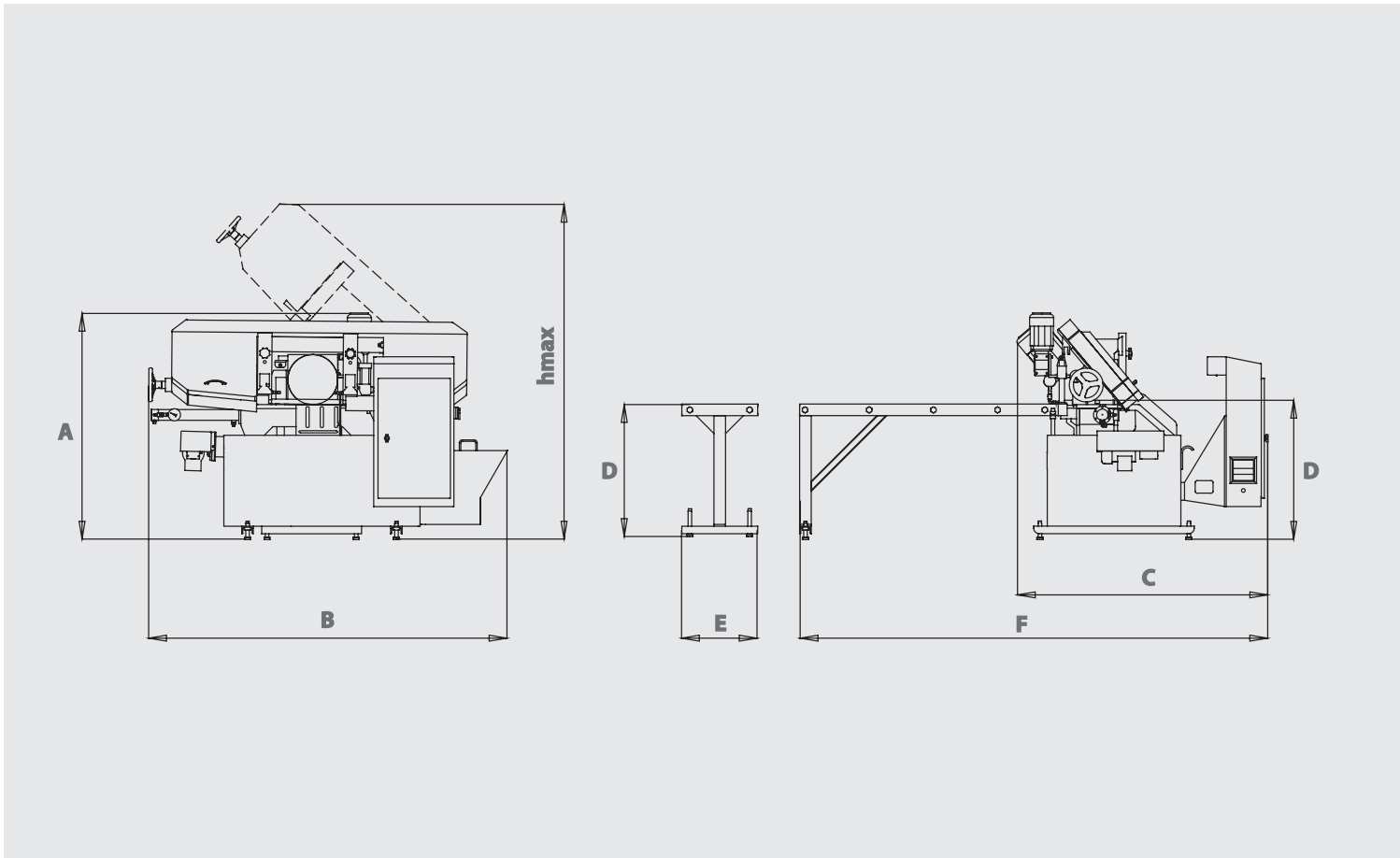



## ÖLÇÜLER DIMENSIONS



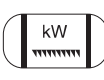
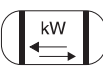
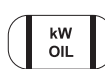
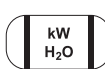





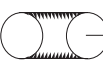

## MAFSALLI MODELLER PIVOT TYPES



## TEKNİK ÖZELLİKLER TECHNICAL FEATURES

A	1215 mm 47.83 inch	B	2010 mm 79.13 inch	C	1410 mm 55.51 inch	D	750 mm 29.53 inch	E	525 mm 20.67 inch	F	2630 mm 103.54 inch	hmax	1850 mm 72.83 inch
---	-----------------------	---	-----------------------	---	-----------------------	---	----------------------	---	----------------------	---	------------------------	------	-----------------------

<b>FLC</b>  Otomatik Automatic	 Şerit Ölçüsü Blade Dimension 27 x 0.9 x 3670 mm 1 x 0.035 x 144.5 inch	 kW Şerit Motoru Blade Motor 1.5 kW - 1500 d/dk 2 hp - 1500 rpm	 kW Sürücü Motor Feeding Motor 0.37 kW - 1000 d/dk 0.49 hp - 1000 rpm
 kW OIL Hidrolik Motor Hydraulic Pump Motor 0.75 kW - 1400 d/dk 1 hp - 1400 rpm	 kW H <sub>2</sub> O Soğutucu Motor Cooling Liquid Motor 0.12 kW - 3000d/dk 0.16 hp - 3000 rpm	 Voltaj Voltage 400 V 400 V	 Maksimum Güç Maximum Power 2.92 kW 3.91 hp
 Kesme Hızı Cutting Speed 15 m/dk - 49 ft/min 130 m/dk - 426 ft/min	 KG LBS Ağırlık Weight 870 kg 1918 lbs	 kW Talaş Konveyörü M Chip Conv. M. 0.18 kW - 1500 d/dk 0.24 hp - 1500rpm	 Şerit Germe Sistemi Blade Tensioning System Hidromekanik Hydramechanic

 Kesim Kapasitesi Cutting Capacity 280 mm 11.02 inch	 Kesim Kapasitesi Cutting Capacity 290 mm 11.42 inch	 mm inch	 60°	 45°	 30°	 0°	 10°	 45°	 60°
						280 mm 11.02 inch			
						250 x 250 mm 9.84 x 9.84 inch			
						150 x 290 mm 5.91 x 11.42 inch			