

PAR 350 M

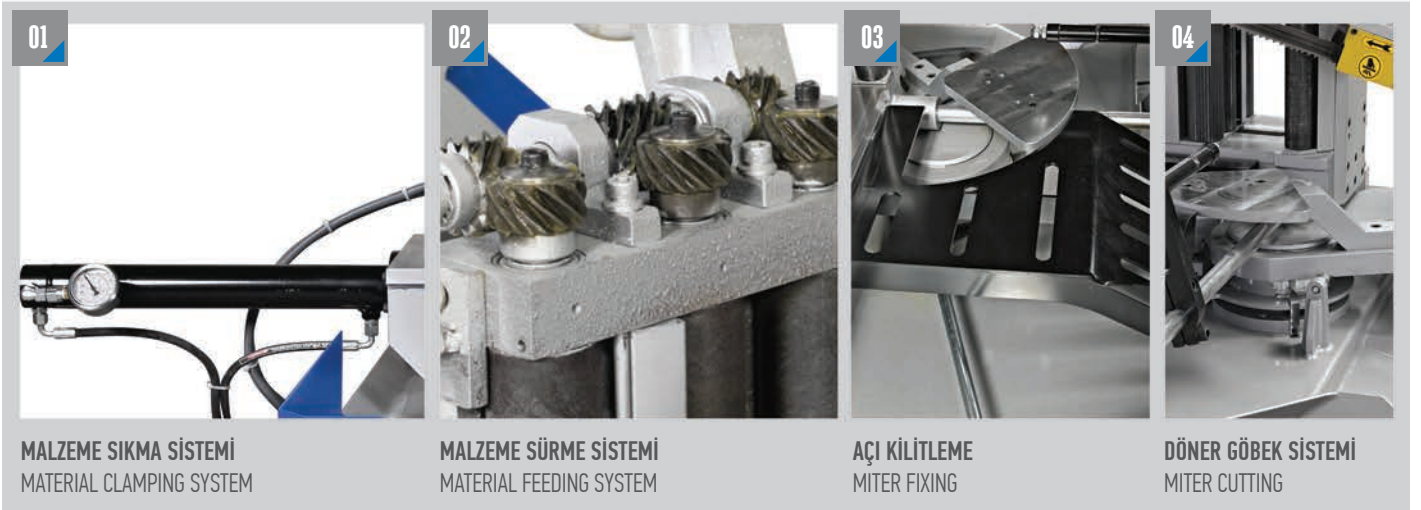

TAM OTOMATİK AÇILI TESTERE TEZGAHI FULL AUTOMATIC MITER BANDSAW MACHINE



ÖLÇÜLER DIMENSIONS

MAFSALLI MODELLER PIVOT TYPES

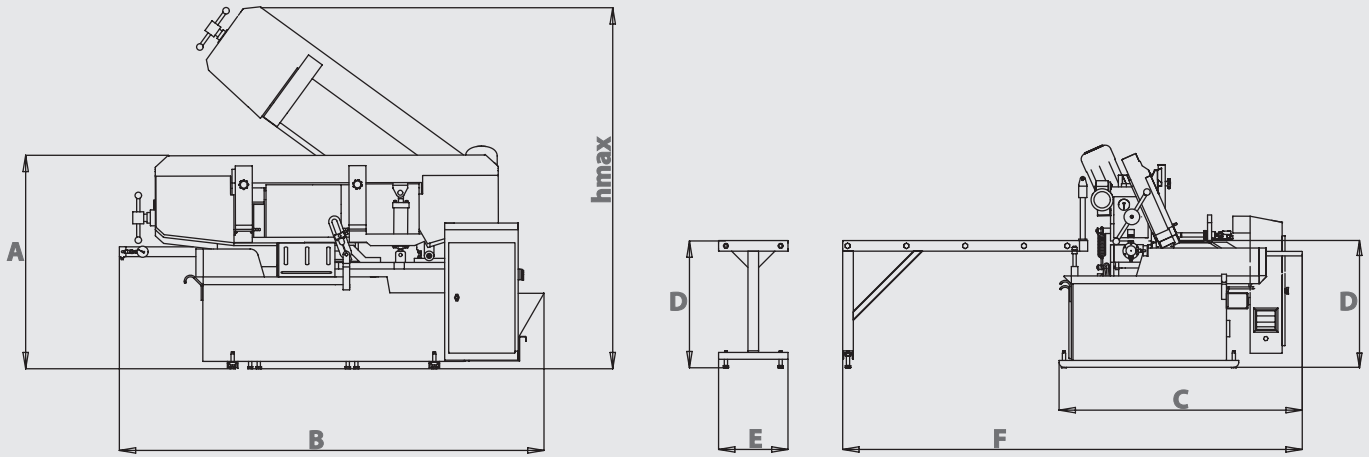

TEKNİK ÖZELLİKLER TECHNICAL FEATURES

A	1370 mm 53.94 inch	B	2600 mm 102.36 inch	C	1480 mm 58.27 inch	D	775 mm 30.51 inch	E	525 mm 20.67 inch	F	2800 mm 110.24 inch	hmax	2150 mm 84.65 inch
---	-----------------------	---	------------------------	---	-----------------------	---	----------------------	---	----------------------	---	------------------------	------	-----------------------

Otomatik Automatic	Şerit Ölçüsü Blade Dimension 34 x 1.1 x 4570 mm 1 1/4 x 0.042 x 180 inch	Şerit Motoru Blade Motor 4 kW - 1500 d/dk 5.36 hp - 1500 rpm	Sürücü Motor Feeding Motor 0.25 kW - 1500 d/dk 0.33 hp - 1500 rpm
Hidrolik Motor Hydraulic Pump Motor 0.75 kW - 1400 d/dk 1 hp - 1400 rpm	Soğutucu Motor Cooling Liquid Motor 0.12 kW - 3000 d/dk 0.16 hp - 3000 rpm	Voltaj Voltage 400 V 400 V	Maksimum Güç Maximum Power 5.12 kW 6.86 hp
Kesme Hızı Cutting Speed 15 m/dk - 115 ft/min 100 m/dk - 230 ft/min	Ağırlık Weight 1150 kg 2335 lbs	Malzeme Sıkma Sistemi Material Clamping System Hidrolik Hydraulic	Şerit Germe Sistemi Blade Tensioning System Hidromekanik Hydramechanic

90°	60°	45°	30°	0°	10°	15°	60°
Kesim Kapasitesi Cutting Capacity 350 mm 13.78 inch	Kesim Kapasitesi Cutting Capacity 460 mm 18.11 inch				350 mm 13.78 inch	350 mm 13.78 inch	320 mm 12.60 inch
					350 x 350 mm 13.78 x 13.78 inch	350 x 350 mm 13.78 x 13.78 inch	300 x 300 mm 11.81 x 11.81 inch
					350 x 460 mm 13.78 x 18.11 inch	250 x 400 mm 9.84 x 15.75 inch	290 x 180 mm 11.42 x 7.09 inch