

PAR 350 U

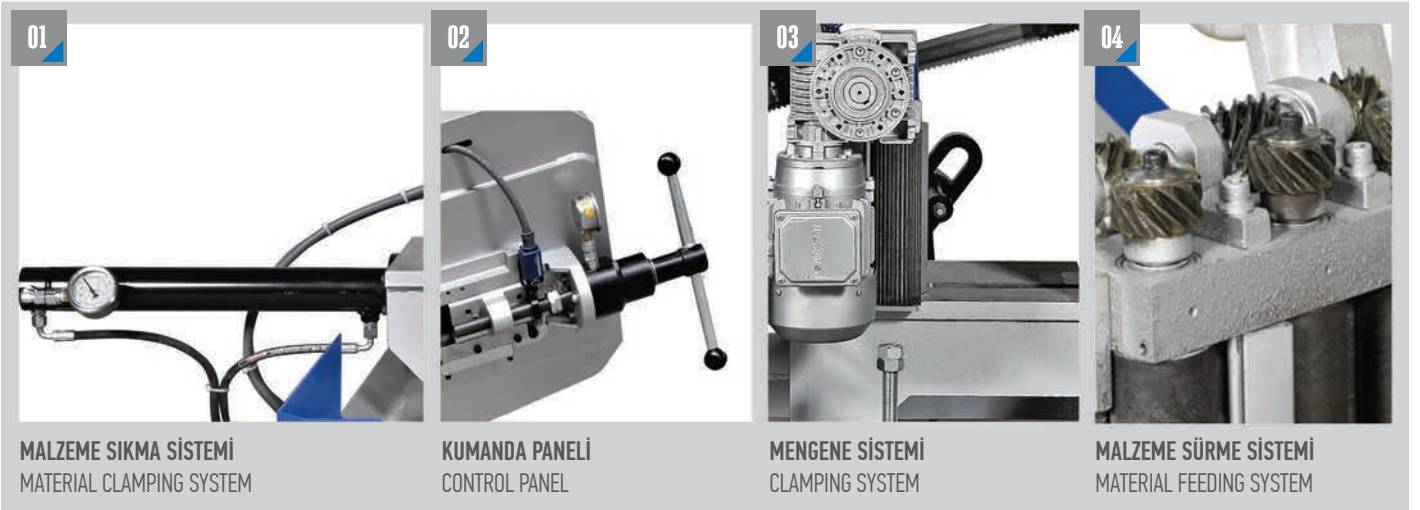

TAM OTOMATİK TESTERE TEZGAHI FULL AUTOMATIC BANDSAW MACHINE



ÖLÇÜLER DIMENSIONS

MAFSALLI MODELLER PIVOT TYPES

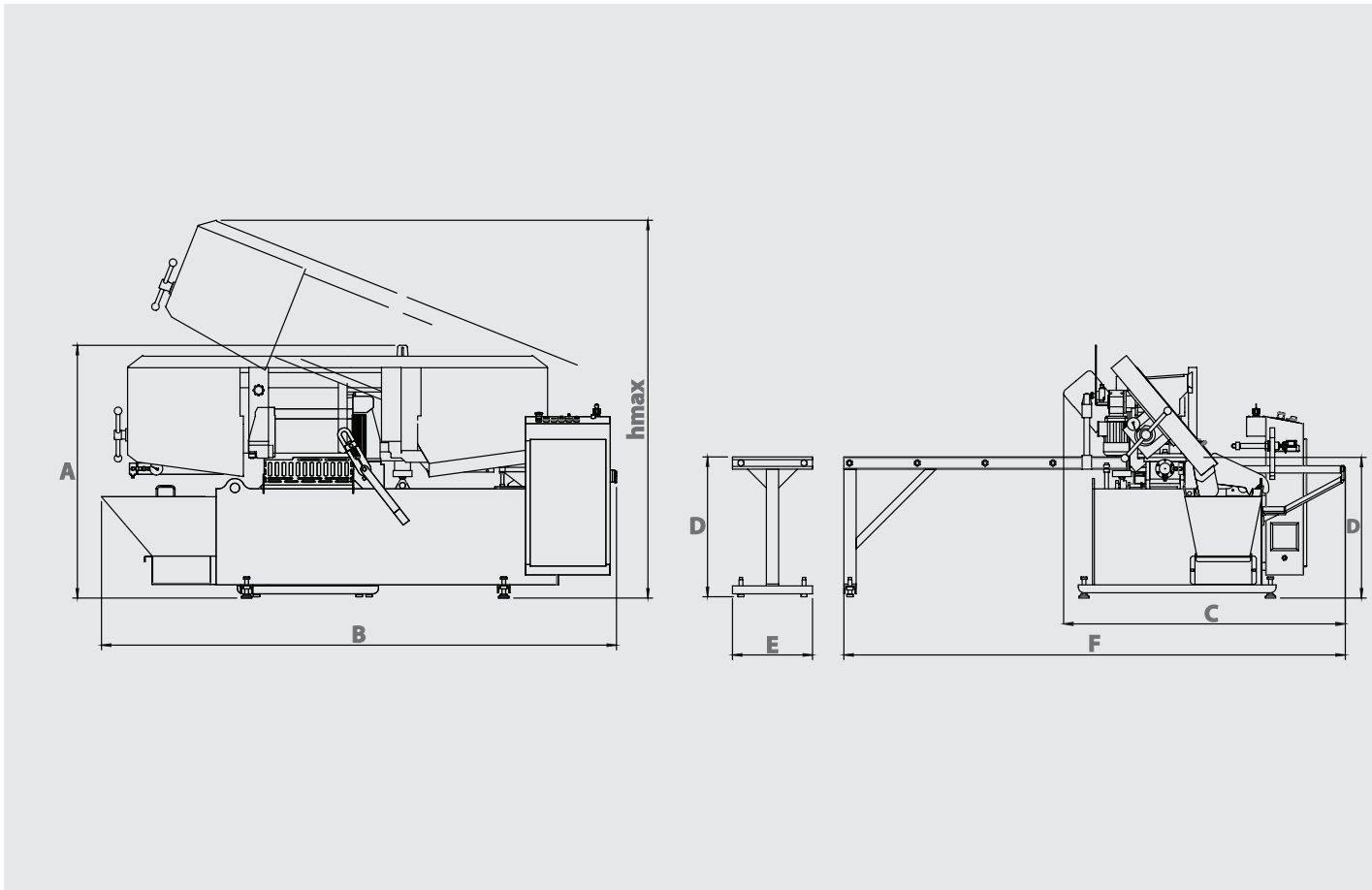

TEKNİK ÖZELLİKLER TECHNICAL FEATURES

A	1340 mm 52.76 inch	B	2735 mm 107.68 inch	C	1465 mm 57.68 inch	D	750 mm 29.53 inch	E	525 mm 20.67 inch	F	2640 mm 103.94 inch	hmax	2010 mm 79.13 inch
---	-----------------------	---	------------------------	---	-----------------------	---	----------------------	---	----------------------	---	------------------------	------	-----------------------

Otomatik Automatic	Şerit Ölçüsü Blade Dimension 41 x 1.3 x 4635 mm 1 1/2 x 0.050 x 182.4 inch	Şerit Motoru Blade Motor 4 kW - 1500 d/dk 5.36 hp - 1500 rpm	Sürücü Motor Feeding Motor 0.25 kW - 1500 d/dk 0.33 hp - 1500 rpm
Hidrolik Motor Hydraulic Pump Motor 0.75 kW - 1400 d/dk 1 hp - 1400 d/dk	Soğutucu Motor Cooling Liquid Motor 0.12 kW - 3000d/dk 0.16 hp - 3000 rpm	Voltaj Voltage 400 V 400 V	Maksimum Güç Maximum Power 5.12 kW 6.86 hp
Kesme Hızı Cutting Speed 15 m/dk - 49 ft/min 100 m/dk - 328 ft/min	Ağırlık Weight 1194 kg 2632 lbs	Malzeme Sıkma Sistemi Material Clamping System Hidrolik Hydraulic	Şerit Germe Sistemi Blade Tensioning System Hidromekanik Hydramechanic

Kesim Kapasitesi Cutting Capacity 350 mm 13.779 inch	Kesim Kapasitesi Cutting Capacity 400 mm 15.748 inch	60°	45°	30°	0°	10°	45°	60°
350 mm 13.78 inch	350 x 350 mm 13.78 x 13.78 inch	200 x 400 mm 7.87 x 15.75 inch						