

# PSM 440 / 610 DM NC



## YARI OTOMATİK ÇİFT YÖN AÇILI TESTERE TEZGAHI SEMI AUTOMATIC DOUBLE MITER BANDSAW MACHINE



## ÖLÇÜLER DIMENSIONS

## MAFSALLI MODELLER PIVOT TYPES

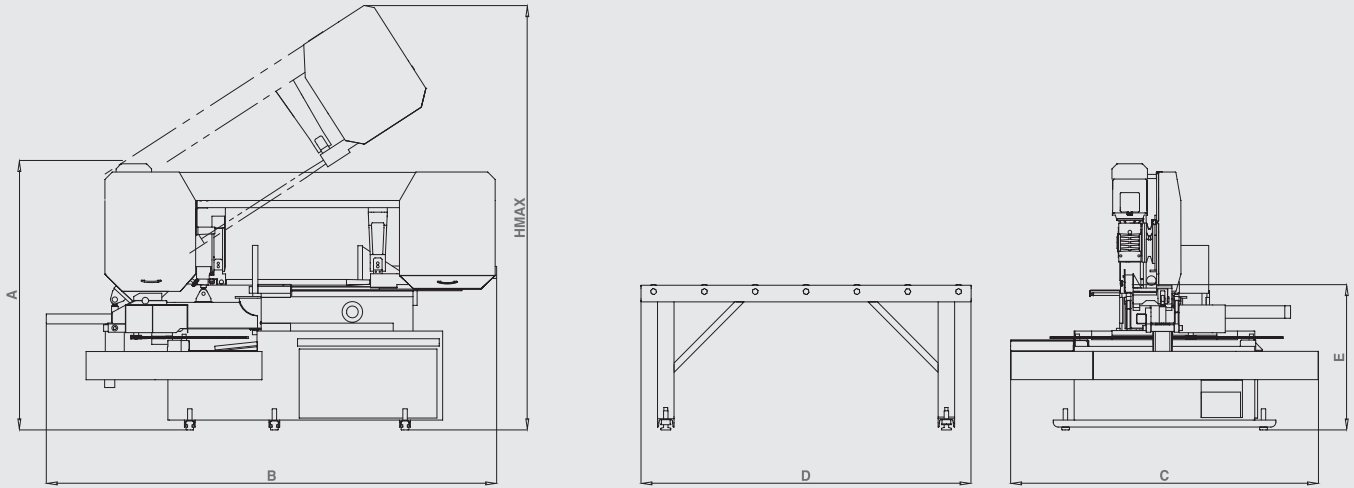

## TEKNİK ÖZELLİKLER TECHNICAL FEATURES

A	1600 mm 62.99 inch	B	2850 mm 112.20 inch	C	1870 mm 73.22 inch	D	2000 mm 78.74 inch	E	860 mm 33.86 inch	hmax	2535 mm 99.80 inch
---	-----------------------	---	------------------------	---	-----------------------	---	-----------------------	---	----------------------	------	-----------------------

Otomatik Automatic	Şerit Ölçüsü Blade Dimension 34 x 1,1 x 5100 mm 1 1/4 x 0,042 x 200,7 inch	Şerit Motoru Blade Motor 4 kW - 1500 d/dk 5.36 hp - 1500 rpm	Sürücü Motor Feeding Motor Manuel Manual
Hidrolik Motor Hydraulic Pump Motor 0.75 kW - 1400 d/dk 0.5 hp - 1400 rpm	Soğutucu Motor Cooling Liquid Motor 0.12 kW - 3000d/dk 0.16 hp - 3000 rpm	Voltaj Voltage 400 V 400 V	Maksimum Güç Maximum Power 4.87 kW 6.53 hp
Kesme Hızı Cutting Speed 15 m/dk - 49 ft/min 100 m/dk - 328 ft/min	Ağırlık Weight 1680 kg 3703 lbs	Malzeme Sıkma Sistemi Material Clamping System Hidrolik Hydraulic	Şerit Germe Sistemi Blade Tensioning System Hidromekanik Hydramechanic

90°		mm	inch	60°	45°	30°	0°	15°	45°	60°
Kesim Kapasitesi Cutting Capacity	Kesim Kapasitesi Cutting Capacity	●		250 mm 9.84 inch	400 mm 15.75 inch	440 mm 17.32 inch	440 mm 17.32 inch	440 mm 17.32 inch	400 mm 15.75 inch	260 mm 10.24 inch
440 mm 17.32 inch	610 mm 24.02 inch	■		250 x 250 mm 9.84 x 9.84 inch	380 x 380 mm 14.96 x 14.96 inch	440 x 440 mm 17.32 x 17.32 inch	440 x 440 mm 17.32 x 17.32 inch	440 x 440 mm 17.32 x 17.32 inch	380 x 400 mm 14.96 x 15.75 inch	260 x 260 mm 10.24 x 10.24 inch
		■		440 x 240 mm 17.32 x 9.45 inch	380 x 400 mm 14.96 x 15.75 inch	440 x 500 mm 17.32 x 19.69 inch	440 x 610 mm 17.32 x 24.02 inch	440 x 500 mm 17.32 x 19.69 inch	380 x 400 mm 14.96 x 15.75 inch	440 x 240 mm 17.32 x 9.45 inch