

# HSC 460



## TAM OTOMATİK HIZLI KESİM SÜTUNLU TESTERE TEZGAHI FULL AUTOMATIC HIGH SPEED CUTTING DOUBLE COLUMN BANDSAW MACHINE



## ÖLÇÜLER DIMENSIONS

## YÜKSEK HIZLI KESİM MODELLERİ HIGH SPEED CUTTING TYPES

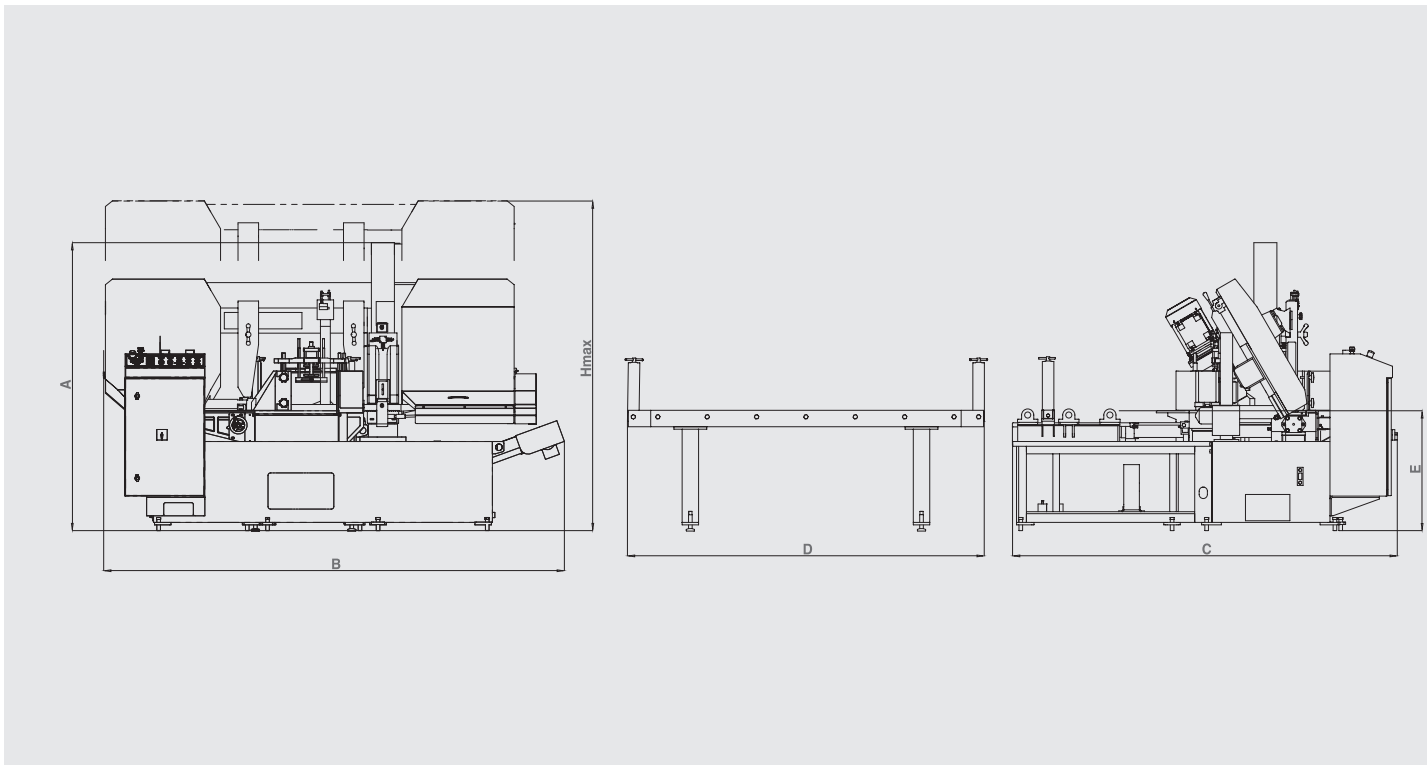

## TEKNİK ÖZELLİKLER TECHNICAL FEATURES

A	1720 mm 68.50 inch	B	2810 mm 110.63 inch	C	2345 mm 92.32 inch	D	2170 mm 85.43 inch	E	710 mm 27.95 inch	hmax	1970 mm 77.56 inch
---	-----------------------	---	------------------------	---	-----------------------	---	-----------------------	---	----------------------	------	-----------------------

Otomatik Automatic	Şerit Ölçüsü Blade Dimension 41 x 1.3 x 5450 mm 1.61 x 0.051 x 214.57 inch	Şerit Motoru Blade Motor 4 kW - 1400d/dk 5.36 hp - 1400 rpm	Talaş Fırçası M. Chip Brush M. 0.09 kW - 1400 d/dk 0.12hp - 1400 rpm
Hidrolik Motor Hydraulic Pump Motor 1.5 kW - 1500 d/dk 2.01 hp - 1500 rpm	Soğutucu Motor Cooling Liquid Motor 0.37 kW - 2850 d/dk 0.33 hp - 2850 rpm	Talaş Konveyörü Motoru Chip Conveyor Motor 0.18 kW - 1400 d/dk 0.24 hp - 1400 rpm	Maksimum Güç Maximum Power 6.14 kW 8.23 hp
Kesme Hızı Cutting Speed 18 m/dk - 59 ft/min 90 m/dk - 295 ft/min	Ağırlık Weight 2666 kg 5877 lbs	Voltaj Voltage 400 V 400 V	Malzeme Sıkma Sistemi Material Clamping System Hidrolik Hydraulic
Şerit Germe Sistemi Blade Tensioning System Hidrolik Hydraulic			

Kesim Kapasitesi Cutting Capacity 460 mm 18.11 inch	Kesim Kapasitesi Cutting Capacity 500 mm 19.69 inch							

Paket Kesim Kapasitesi Total Cutting Capacity 120 - 230 mm 5 - 9 inch	Paket Kesim Kapasitesi Total Cutting Capacity 195 - 310 mm 8 - 12 inch							



## HSC 460 & HSC 460 ALU



01

### ŞERİT KOPMA SENSÖRÜ

Kasnağa yerleştirilen sensör yardımıyla şerit koptuğu durumlarda makinenin otomatik olarak durması sağlanır.

#### BLADE BREAKAGE SENSOR

This sensor in the idle pulley stops the machine automatically when the blade is broken.

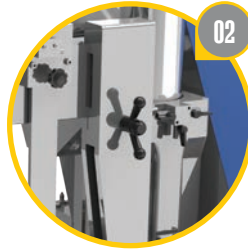

02

### OTOMATİK YÜKSEKLİK AYARI

Testere kafasının malzemeye hızlı yaklaşmasını ve herhangi bir yükseklik ayarına gerek kalmadan kesme yüksekliğine otomatik kalkmasını sağlar.

#### AUTOMATIC HEIGHT CONTROL

Automatic work height control by fast approach bar sensor



03

### KESME BASINÇ AYARI

Malzemenin özelliğine göre testerenin kesme basıncı ayarlanabilir.

#### CUTTING PRESSURE

Cutting pressure can be adjusted according to material's hardness.

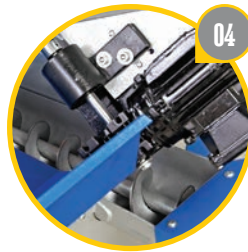

04

### TALAŞ KONVEYÖRÜ

Kesim arasında oluşan talaşları otomatik uzaklaştırmaya yarar.

#### CHIP CONVEYOR

Chip conveyor conveys accumulated chip to portable chip box



05

### PLC KONTROL

Tüm elektrik ve hidrolik fonksiyonlar PLC kontrol ünitesi ile sağlanır.

#### PLC CONTROL

PLC control for all electrical and hydraulic functions



06

### TALAŞ FIRÇASI

Motor tahrikli talaş fırçası yardımıyla şerit dişleri arasındaki talaşların temizliği sağlanır.

#### CHIP BRUSH

Motorized chip brush cleans all chips in the blade teeth.



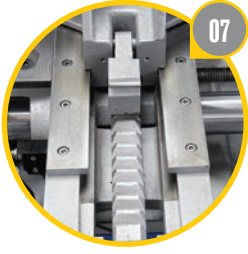

07

**MENGENE SİSTEMİ**

Hareketli mengenerler, el yardımıyla kesilecek malzeme genişliğine göre kaydırılarak ayarlanabilir.

**CLAMPING SYSTEM**

Movable clamps can be adjusted manually according to material's diameter or width.



08

**DAYAMASIZ KESİM**

Özel sayıcı vasıtasıyla kesilen malzemenin boyu hassas olarak ayarlanabilir.

**ACCURATE CUTTING**

Accurate length measuring by special counter



09

**HIZLI KESİM**

Ön ve arka mengenerler üzerine kolaylıkla monte edilebilen hidrolik üst baskı ile paket kesim yapma imkânı.

**BUNDLE CUTTING**

Bundle cutting can be done by hydraulic bundle clamping, which is easily mountable on front and back clamps.

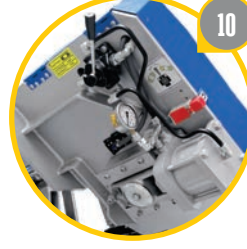

10

**ŞERİT GİRDİRME**

Hidrolik kumandalı şerit gerdirme sistemi ile kesim esnasında şeridin sürekli aynı gerginlikte olmasını sağlar.

**BLADE TENSIONING**

Hydraulic blade tensioning system makes it possible to put the blade tension at the same level during cutting.



11

**ÇİFT MENGENE**

Besleme arabası üzerindeki her iki mengene de hidrolik olarak kumanda edilebilir.

**SHUTTLE VISE**

Shuttle vise on the feeding bar can be controlled hydraulically.



12

**KUMANDA PANELİ**

Kullanıcıya kolaylık sağlayan ergonomik kontrol paneli.

**CONTROL PANEL**

Easy to use, ergonomic control panel.

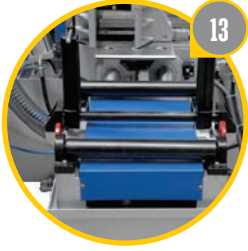

13

**MALZEME BESLEME SİSTEMİ**

Malzeme beslemesi hidrolik silindir yoluyla hassas olarak yapılır.

**FEEDING SYSTEM**

Accurate material feeding by hydraulic cylinder

